



Alfa V 800, 910 & 1000 mm

Dry Cooler VDD / VDD6

Applications

Refrigeration and air conditioning applications:

- water / glycol cooling
- free cooling

Industrial applications:

- cooling of water or other different liquids
- food, power, process and general industry.

Heat exchanger

Optimized "V type" design provides large capacity with compact size. Innovative heat exchanger design gives excellent heat transfer with minimized refrigerant charge, thanks to the new fins corrugation, developed by Alfa Laval, combined with two different tube sizes 1/2" (VDD series) and 5/8" (VDD6 series). In the standard execution, heat exchanger manufactured from copper tubes and aluminium fins with spacing 2.1 mm. Double connection provides opportunity for two completely independent heat exchangers. Each heat exchanger undergoes a pressure and leaking test with dry air at 11 bar.

Fan motor

Three different fan diameters available: 800, 910 and 1000 mm with three-phase motor 400V-50Hz. The motors are with external rotor, made in accordance with VDE 0530/12.84, IP54. These Dry Coolers are available in five noise levels fan motor, (S) standard, (L) low, (Q) quiet, (R) residential and the new (T) high performance fan dry coolers VDD/VDD6 800 and 910 are available in 4 noises level fan motor, (S) standard, (L) low, (Q) quiet and (R) residential. Dry Coolers VDD/VDD6 1000 are available in 3 noises level fan motor, (L) low, (Q) quiet and (R) residential. New bell mouths optimize the performance of the fan motors and minimize the noise level. Each fan chamber is separated by internal baffle plates which enables optimal capacity control by separate running of the fans.

Frame and casework

Casework made with galvanized steel sheets painted (corrosion resistance class C4) with epoxy finish, RAL 9002. New design frame provides high rigidity also for heavy applications. New system perfectly protects the heat exchanger tubes during transportation and operation against vibration and thermal expansion. Support manufactured in galvanized steel.



Alfa V Dry Cooler VDD series

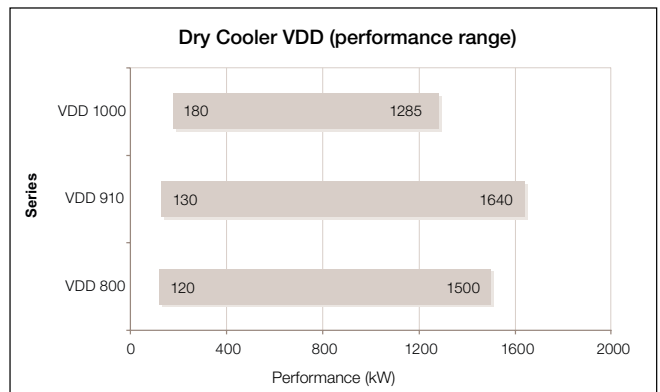

Code description

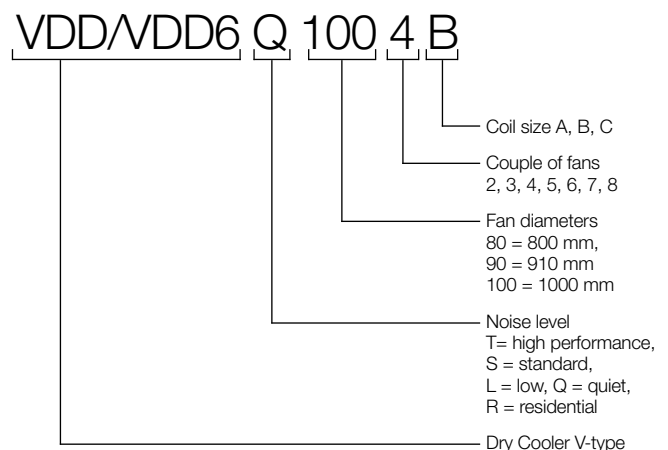

FEATURES AND BENEFITS

Footprint

- Smaller footprint with more capacity

800, 910 and 1000 mm fan diameter

- More performance available
- More choice on noise level
- Flexible design

All parts painting RAL 9002

- No cut edges
- Higher corrosion resistance class (C4)

Coil design

- Increased heat transfer thanks to innovative fins corrugation

Flanges UNI EN 1092-1 in stainless steel

- Easy and accurate piping connections
- Different standard codes available

High energy efficiency

- Best performance with low energy consumption

OPTIONS

Non standard fin spacing

- For heavy dusty environments

Coil treatment

- Corrosion resistance
- Useful for aggressive environments

Spray water device

- Possibility to select smaller units
- Keep the performance during temperature peaks

Vibration dampers

- Useful to reduce vibrations

SPECIAL FANS

EC fans

- Best alternative for frequency converter control 480/3 ph-60 Hz IP54
- High adaptability on every market

IP55

- High protection fan to be used in tropical or desert areas

ELECTRICAL PARTS

- Switch on/off
- Local safety switch wired to isolate the fan, EMC switch also available

Terminal box

- All fans are wired for an easy electrical connection

Switchboard

- Manufacture reliability
- Corrosion/Shock/Condensation/UV resistance
- Wide range of solutions
- IP66 for casing, IP56 for switchboard
- 100% recyclable

Cabling

- Ready for installation

Design for frequency converter

- Units can run under frequency control (when air temperature is below the design it permits energy saving, noise reduction and longer fan motor lifetime)

Fan step control

- Energy saving
- Better control of performance

Fan speed control

- Energy saving
- Noise reduction when air temperature is below design temperature
- Variable and fine control of velocity according to heat reject

Dimensions

Model	Dimensions (mm)	...02	...03	...04	...05	...06	...07	...08
VDD/VDD6 800/910/1000	H	2280	2280	2280	2280	2280	2280	2280
	L	2940	4250	5560	6870	8180	9490	10800
	W	2230	2230	2230	2230	2230	2230	2230

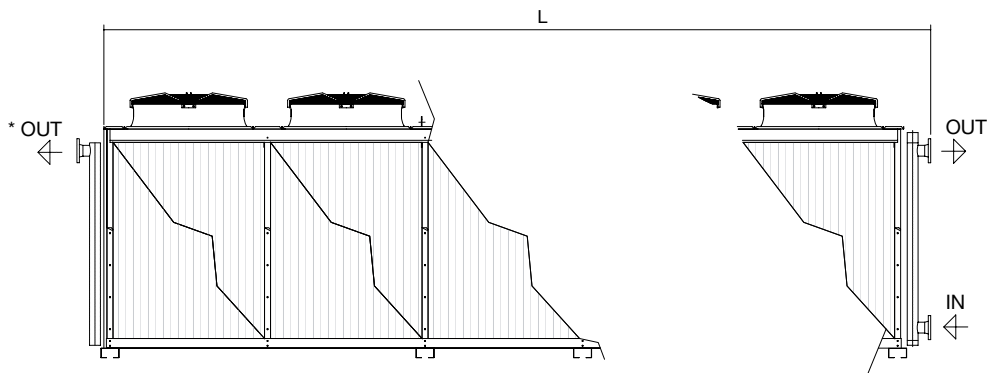
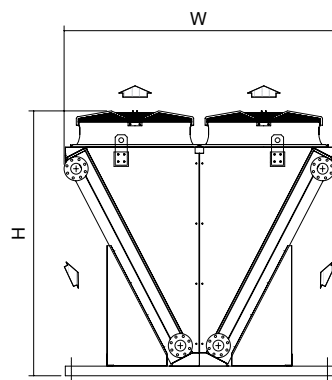

PCT00067EN 0703

All rights reserved for changes in specifications

How to contact Alfa Laval

Up-to-date Alfa Laval contact details for all countries are always available on our website at www.alfalaval.com

